

Words

1 Complete the animal words. Listen and number.  03



s _ _ _ e _ _



b _ _ _ _

We're going to the zoo today.



c r o c o d i l e



t _ _ _ _



s _ _ _ _



m _ _ _ _ _

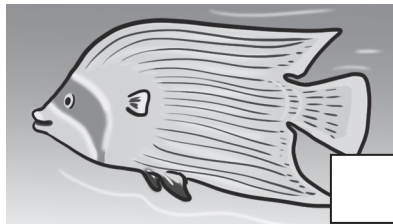

f _ _ _ _



g _ r _ f _ e



h _ p _ o



l _ z _ _ d

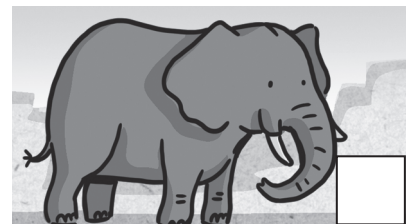

e _ _ _ _ _

2 Which animal don't the children talk about?

1 Match the pictures and words. Say.



zoo

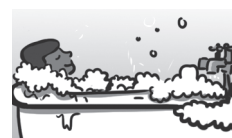

school



home



park



shops



see / a giraffe choose / shoes write / stories
 have / a bath ride / a bike fly / a kite
 buy / a book take / photos eat / lunch

You can write stories at school.

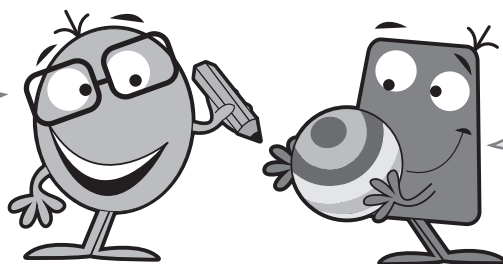

And you can ride a bike at the park.

2 Read and write answers.

- 1 Would you like to go to the zoo? Yes, I want to see the giraffes.
- 2 Would you like to go to the shops? _____
- 3 Would you like to go home? _____
- 4 Would you like to go to the park? _____

1 Listen and read. Then act. 🎧 04

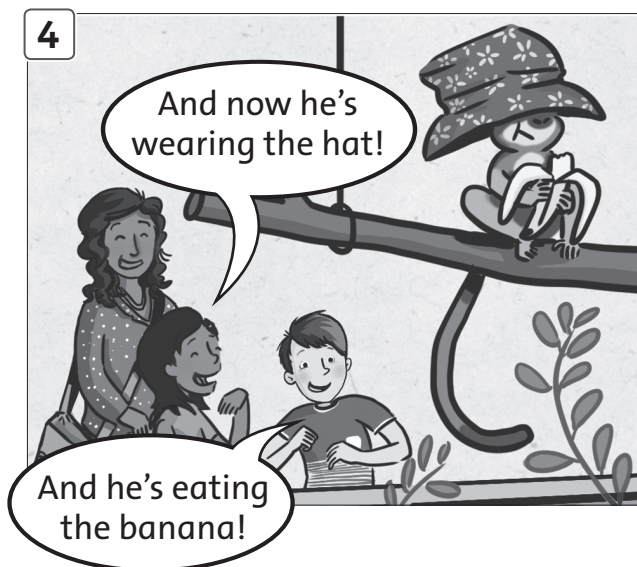

2 Look and say.

drinking eating
~~sleeping~~ swimming

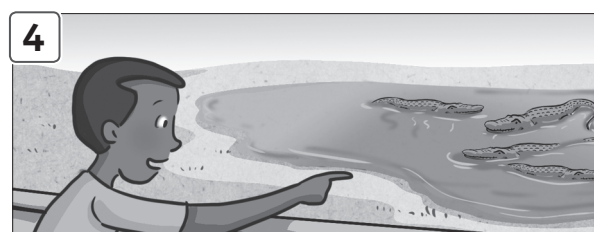
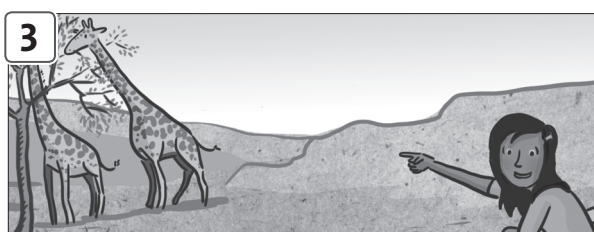

1 Write the answers to find the animal.

1 

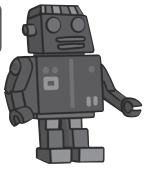
2 

3 

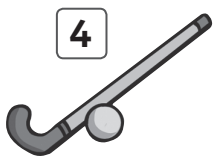
4 

↓

1	s	o	c	k					
			2						
		3							
			4						
	5								
			6						
			7						
			8						
			9						

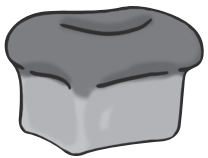
9 

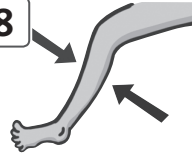
8 

7 

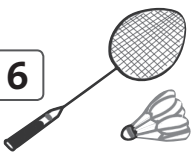
6 

5 

2 Find the animals.

t	c	l	h	p	c	i	d	e	f
i	o	g	i	r	a	f	f	e	l
g	w	z	p	z	t	c	b	s	r
e	l	e	p	h	a	n	t	r	e
r	r	d	o	l	j	r	h	o	d
m	o	n	k	e	y	m	d	h	i
e	q	f	i	s	h	e	b	m	p
c	r	o	c	o	d	i	l	e	s

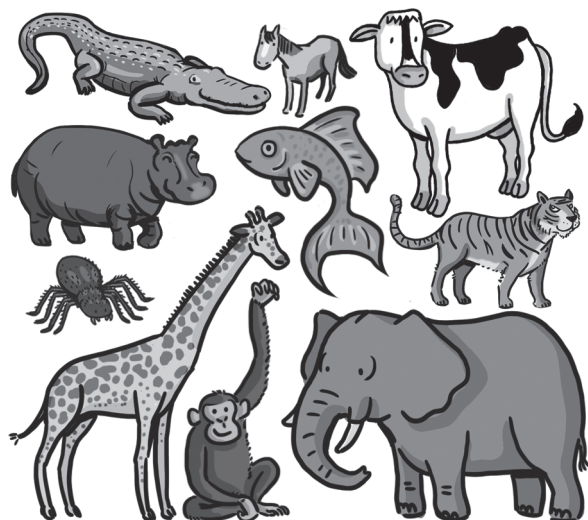

Reading & Writing, Part 5

Look at the pictures and read the questions. Write one-word answers.



Examples

Where's the bird?

next to the sun

How many giraffes are there?

two

Questions

1 How many monkeys are there?

2 Where's the baby giraffe?

its mother



3 How many flowers are there?

4 Which animal is on the hippo?

the _____





5 Where's the snake?

in the _____

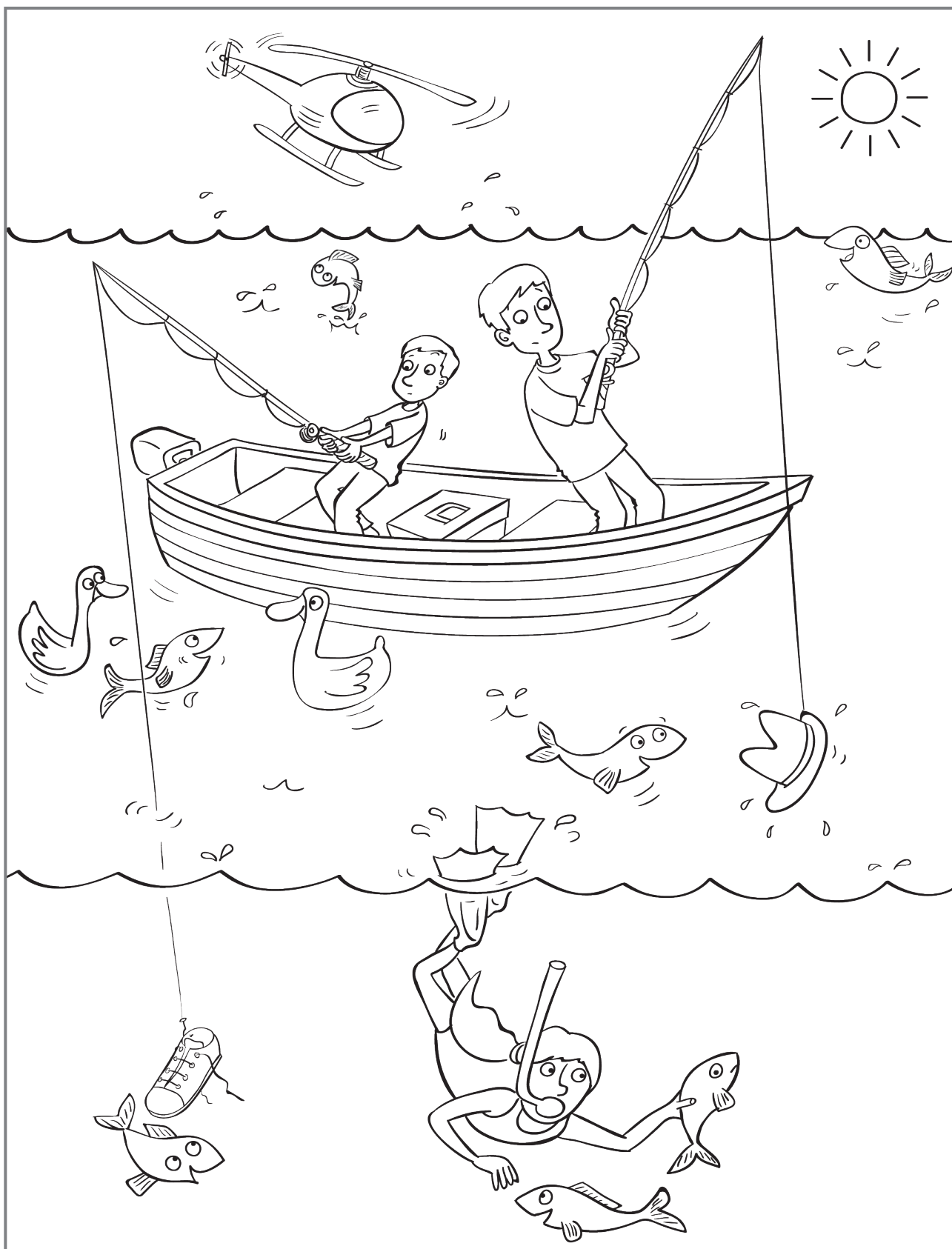
Listening, Part 4

Listen and colour.  05

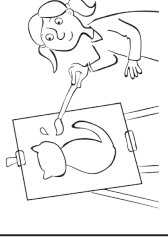

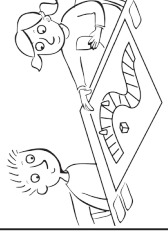
							
							
							
							
							
							
Name							

There's and There are

*There are four rooms.
There's a bed.
There's a cupboard.*

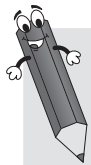

We use **there's** and **there are** to talk about things around us.

We use **there's** to talk about one thing or person.

There's a bed. There's a cupboard.

We use **there are** to talk about two or more things or people.

There are four rooms.

there's = there is



1 Match.

- 1 There are two toy boxes. e
- 2 There's a toy box.
- 3 There's a doll.
- 4 There are three dolls.
- 5 There are four books.
- 6 There's a book.

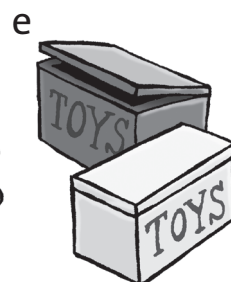
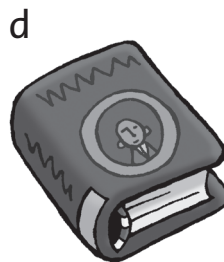
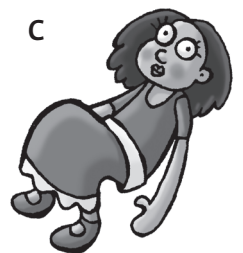
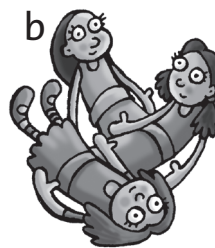

2 Write the words in the correct box.

~~a bed~~ ~~eight books~~ two pillows a cupboard five pencils
ten cars a doll six puzzles a shelf a blanket

There's

a bed

There are

eight books

3 Count. Write sentences.

- 1 There's one teddy.
- 2 There are five dolls.
- 3 _____ balls.
- 4 _____ puzzle.
- 5 _____ kite.
- 6 _____ books.
- 7 _____ bed.
- 8 _____ shelf.

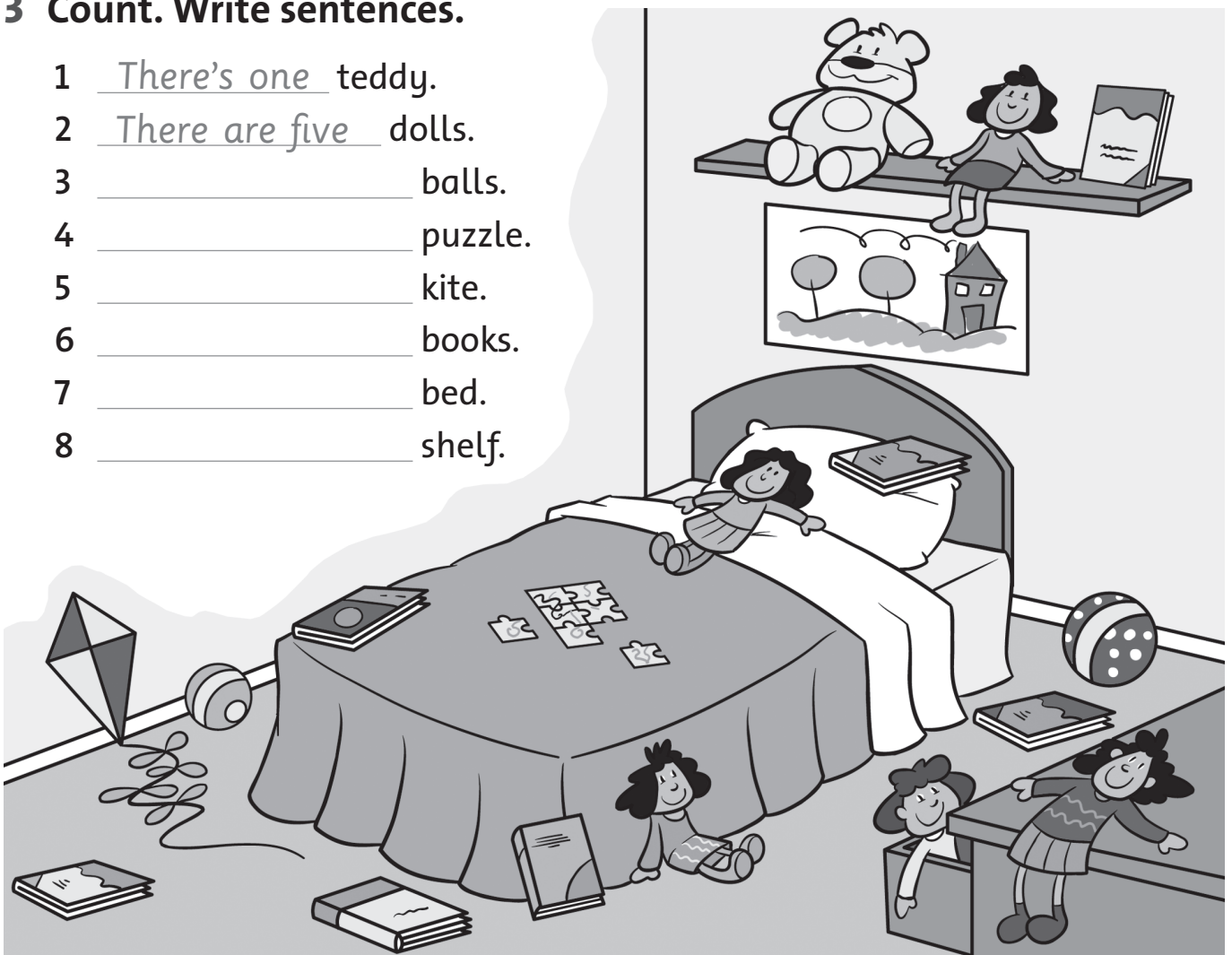

Is there ...?

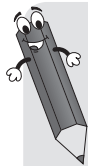

Is there ...? is a yes/no question. We can use Is there ...? to ask about things around us.

We change the word order in questions.

There's a pillow on the bed.

Is there a pillow on the bed?

4 Write the words in the correct order. Make questions.

1 there Is a pillow

Is there a pillow _____?

2 there Is a toy box

_____?

3 shelf a Is there

_____?

4 a bed there Is

_____?

5 a Is cupboard there

_____?

6 rug Is a there

_____?

Yes, there is. / No, there isn't.

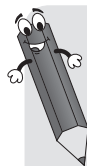
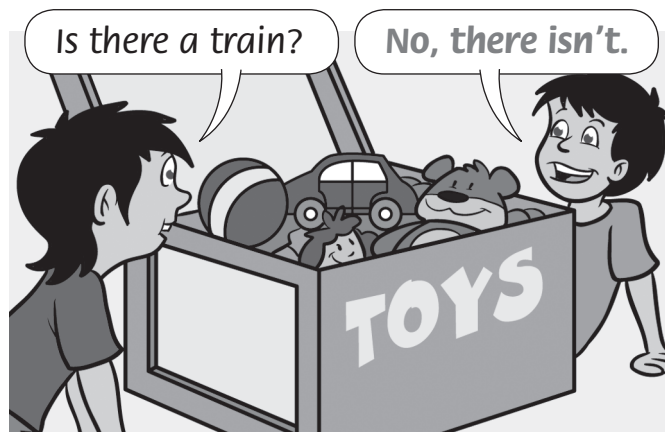
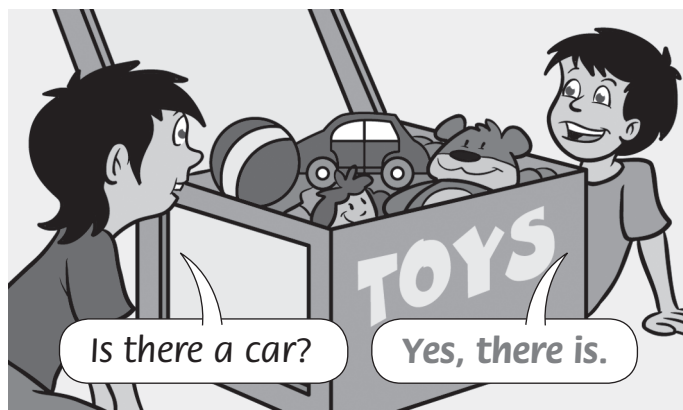

Yes, there is and No, there isn't are short answers. We can use them if the question begins *Is there ...?*

Is there a ball?
Yes, there is.
No, there isn't.

No, there isn't. = No, there is not.



5 Tick (✓) the correct short answer.

- | | | |
|------------------------|------------------|-------------------------------------|
| 1 Is there a bed? | No, there isn't. | <input type="checkbox"/> |
| | Yes, there is. | <input checked="" type="checkbox"/> |
| 2 Is there a shelf? | No, there isn't | <input type="checkbox"/> |
| | Yes, there is. | <input type="checkbox"/> |
| 3 Is there a toy box? | No, there isn't. | <input type="checkbox"/> |
| | Yes, there is. | <input type="checkbox"/> |
| 4 Is there a cupboard? | No, there isn't. | <input type="checkbox"/> |
| | Yes, there is. | <input type="checkbox"/> |



6 Look and write.

Yes, there is. No, there isn't.

- | | |
|----------------------------------|-----------------------|
| 1 Is there a car on the shelf? | Yes , there is _____. |
| 2 Is there a ball on the shelf? | _____. |
| 3 Is there a blanket on the bed? | _____. |
| 4 Is there a cupboard? | _____. |

1 Listen and look at the pictures. Circle A, B, or C.  06

Example

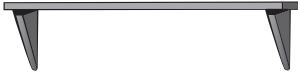

(A)

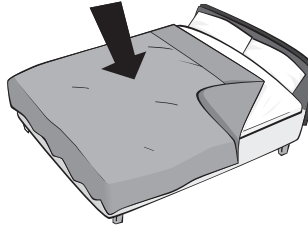

(B)

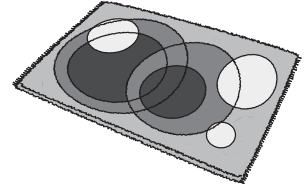

(C)

1

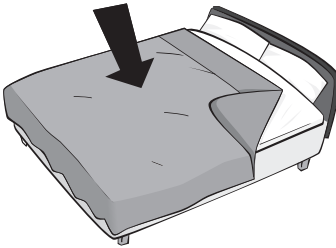

(A)



(B)

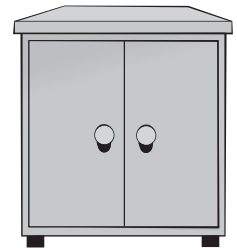

(C)

2

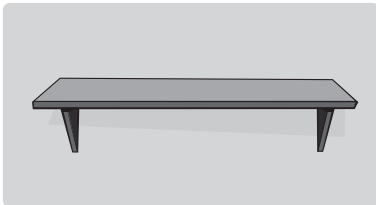

(A)

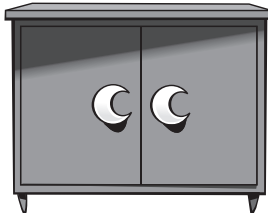

(B)

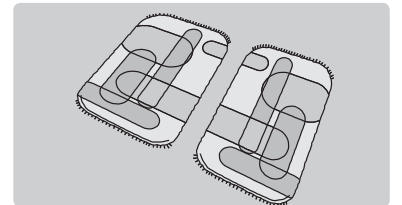

(C)

3



(A)

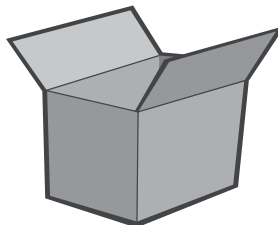

(B)

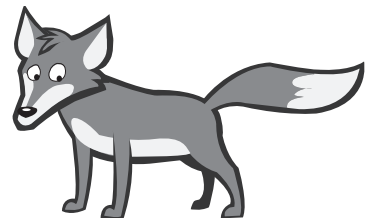

(C)

2 Listen. Which sentence or conversation sounds correct? Circle A, B or C. 07

Example

(A)

 (B)

(C)

1

(A)

(B)

(C)

2

(A)

(B)

(C)

3

(A)

(B)

(C)

3 Listen and read. Circle A, B, or C. 08

Example

 (A)

Anh lives in an apartment.

(B)

Anh lives in a house.

(C)

Anh lives in a school.

1

(A) Anh's sister is in the bedroom.

(B) Anh's mom is in the kitchen.

(C) Anh's sister is in the living room.

2

(A) Anh likes books.

(B) Anh has six books.

(C) Anh's favorite book is red.

3

(A) Anh's favorite toy is a teddy bear.

(B) Anh's favorite toy is a doll.

(C) Anh's favorite toy is a train.

4 Listen and draw.  09

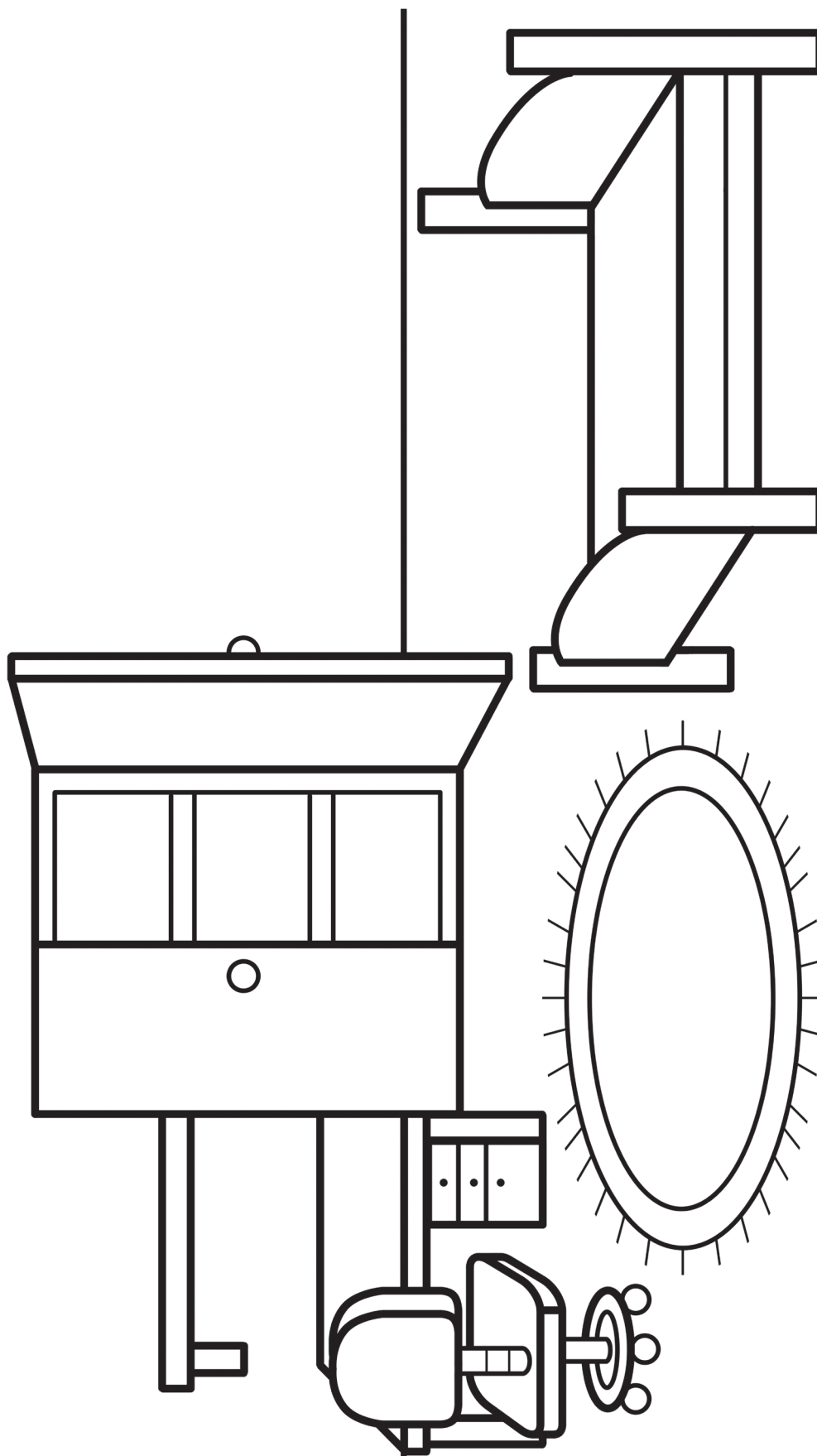

1 Look and circle. Write.

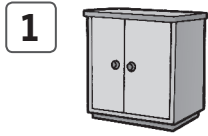

cabinet

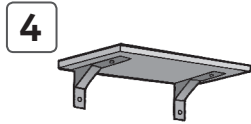

e	i	g	h	t	e	e	n	★	f
c	a	b	i	n	e	t	★	★	i
★	★	★	★	★	★	★	★	s	f
★	t	w	e	l	v	e	★	h	t
★	★	★	★	★	★	★	★	e	e
★	★	p	i	l	l	o	w	l	e
★	★	★	★	★	★	★	★	f	n

2 Look and write.



1 There's a ball under my bed.

2 _____ a train _____ my cabinet.

3 _____ a teddy bear _____ my _____.

4 _____ dolls _____ my rug.

1 Look. Circle the mess in each room.

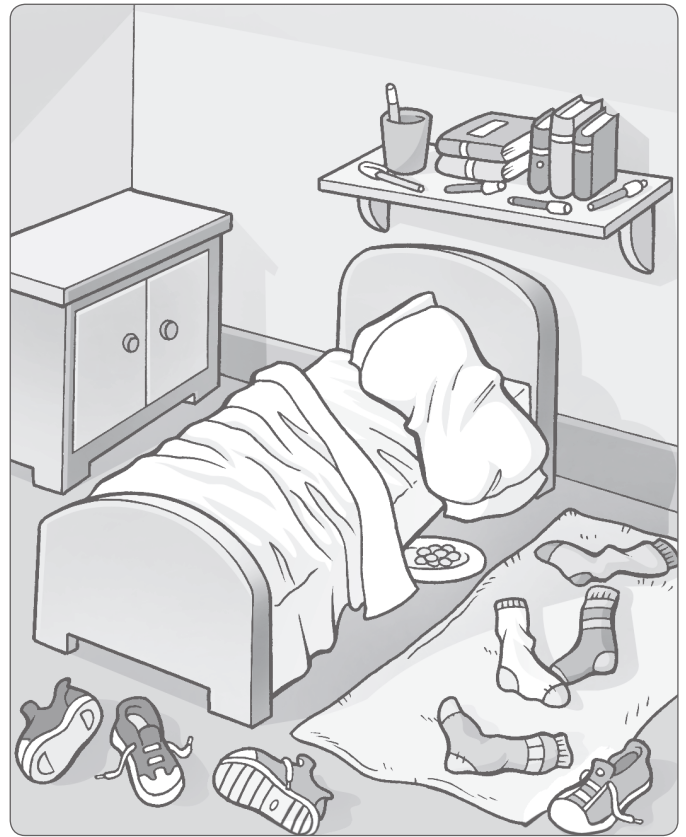

2 Read and draw.

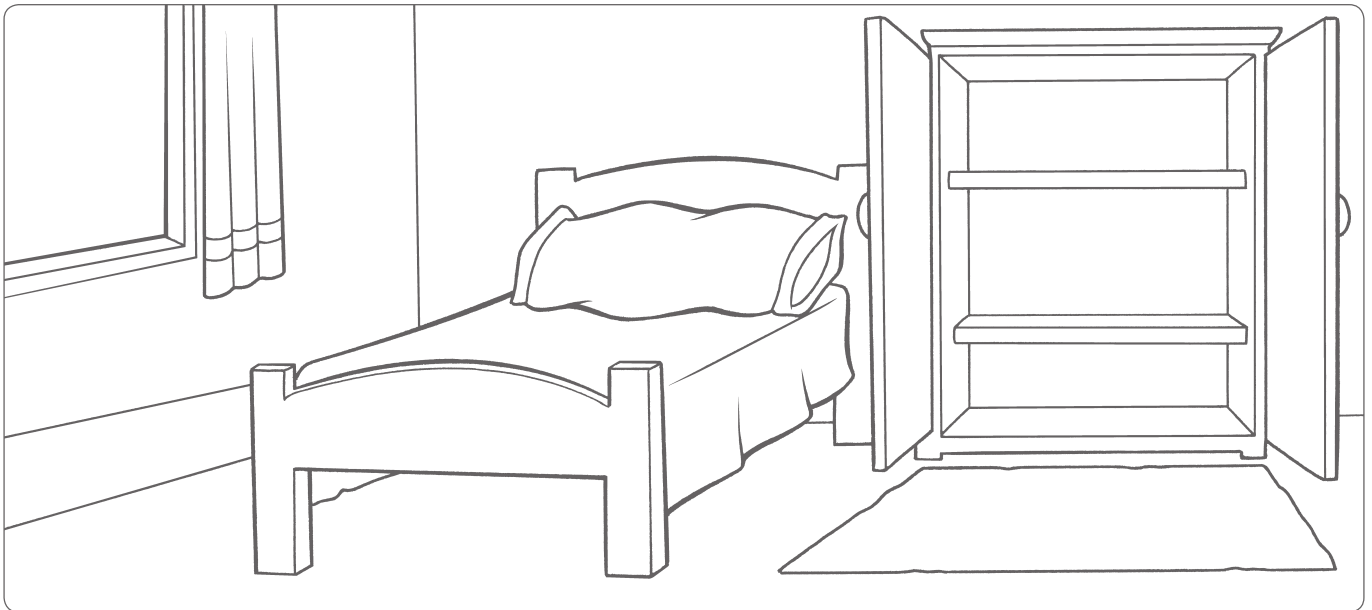

There's a teddy bear on the bed.
There's a ball in the cabinet.

There's a train under the bed.
There are some cars in the cabinet.

1 Complete the words.

/4

1

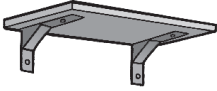

shelf

2



blanket

3



pillw

4



rug

5

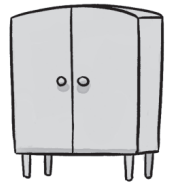

cabnet

2 Write the correct words and numbers.

/4

- 1 svenetnee seventeen
- 2 wtleve _____
- 3 teenffi _____
- 4 entytw _____
- 5 fteenour _____

3 Complete the sentences with *in*, *on*, or *under*.

/3

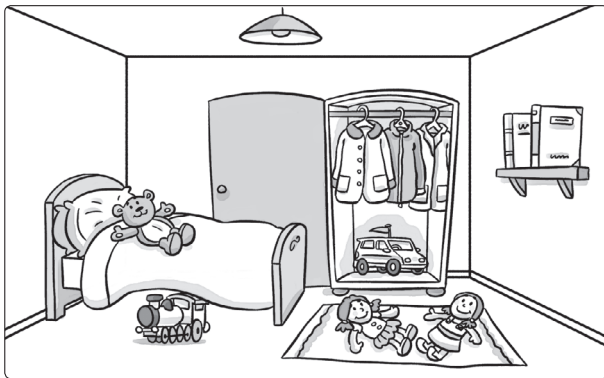

- 1 The books are on the shelf.
- 2 The train is _____ the bed.
- 3 The dolls are _____ the rug.
- 4 The coats are _____ the cabinet.

4 Complete the sentences.

/4

- 1 There's a train under the bed.
- 2 _____ teddy bear _____ the bed.
- 3 _____ three coats _____ the cabinet.
- 4 _____ two books _____ the shelf.
- 5 _____ car _____ the cabinet.

____ /15